

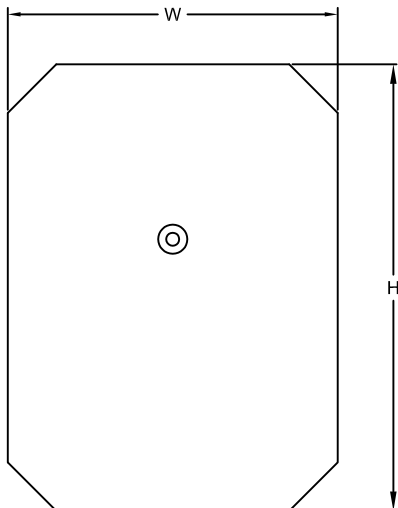

PREPACKAGED ISAM™ SEQUENCING BATCH REACTOR SYSTEMS

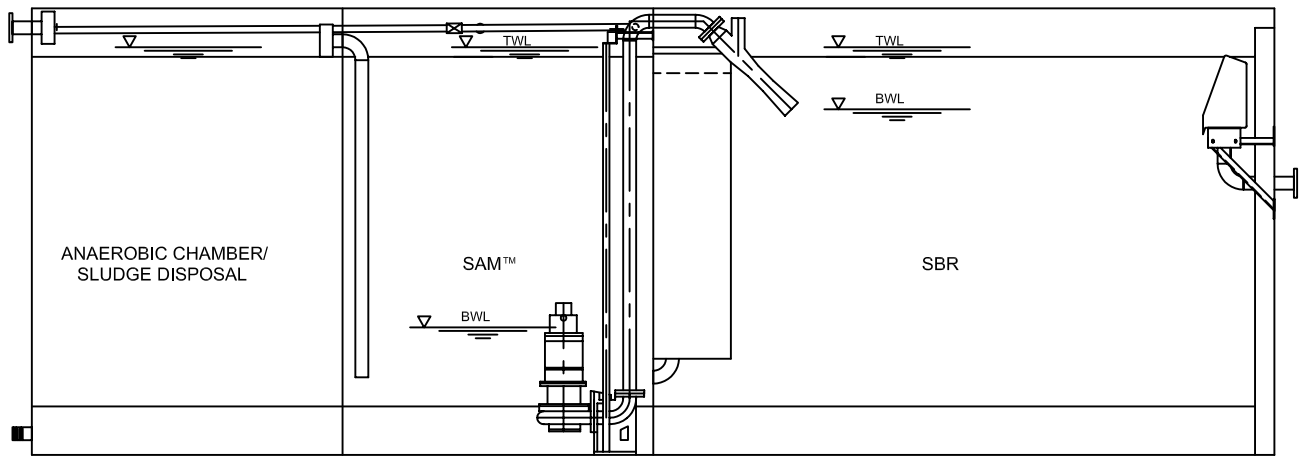
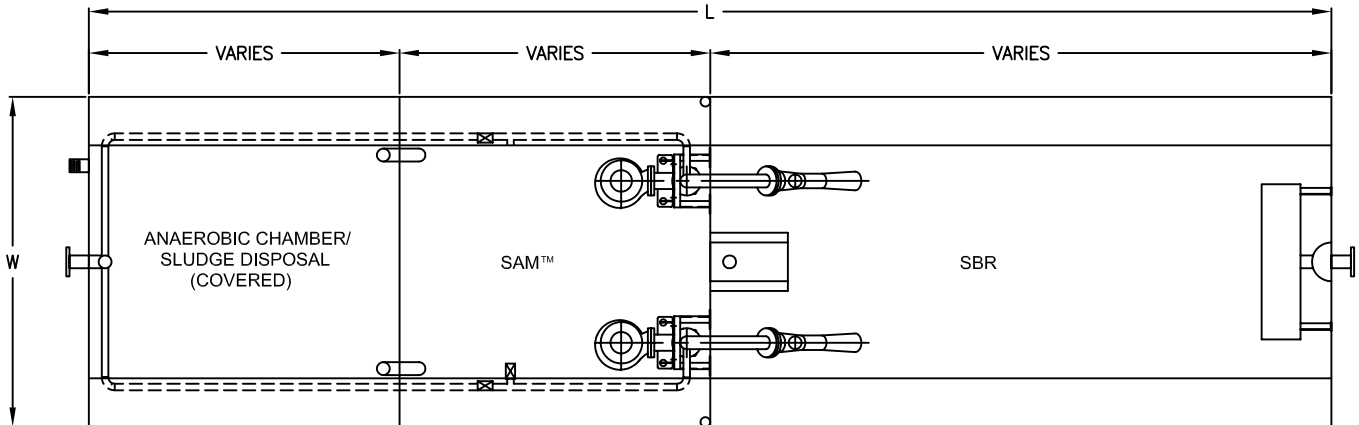

MODEL	W	L	H	HP*
ISAM™ 05	6.5	16	9.5	5
ISAM™ 10	8.5	24	9.5	5
ISAM™ 15	8.5	24	11.5	5
ISAM™ 20	8.5	32	11.5	5
ISAM™ 25	8.5	40	11.5	7.5
ISAM™ 30	11.9	32	11.5	7.5
ISAM™ 40	11.9	45	11.5	10
ISAM™ 50	11.9	56	11.5	10

* EACH PUMP (ONE IS STANDBY)